

Minutes from Nordic Classic Road Racing Meeting 2023

Date: 23rd -24th of September 2023
Venue: Scandic Hotel
Address: Hotellvägen 1, 194 35 Upplands Väsby, Sweden

Participants at the Teams meeting:

Søren Holm	- DMU
Teddy Schulz	- DMU; on Teams for race track discussions
Sören Hannibal	- DMU; on Teams for race track discussions
Tor Henning Molstad	- NMF
Espen J Sandbakken	- NMF
Per Holmström	- Svemo
Osmo Leikko	- SML

Minutes of the Meeting:

1. Opening of the meeting

The meeting was managed by Sweden. Per Holmström opened the meeting.

2. Election of the Chairman of the meeting

Tor-Henning was elected.

3. Election of the Secretary of the meeting

The NMF suggested Per Holmström as Secretary of the meeting.
Per Holmström was elected.

4. Short presentation of everybody

No presentation needed, since we're the same participants as last year.

5. Minutes from the meeting in 2022

The minutes were presented, and no errors were found. It was found that the updated rules haven't been published on the MCHK-racing website. That need to clearly be addressed in this year's MoM.

6. Around the table and status from the FMN's

- **DMU:** Classic TT. Both FIM-E, NO and NC, in May at Ring Djursland, was only a two-day meeting. Also, modern sidecars were part of the meeting. Lot of spectators and journalists. The number of riders was only 129. This race was organized by the track owner and they seems satisfied with the result. 3 national races have been organized, with 45-50 participants, all of them together with cars, with all the usual problems.

282 active licenses in total. The number of riders in the national classic races have been around 50.

- SML:

1. Nordic Round at Botniaring in May, 119 entries
2. First club race at Botniaring in June, 40 entries. Fee 70,- euros and extra class 20,-
3. Second club race at Botniaring in July, 50 entries. Fee 100,- euros and extra class 30,-
4. Third club race at Alastaro Circuit in August, 91 entries. Fee 100,- euros and extra class 30,-
 - Pyynikki Classic TT event with legends and Parade
5. Fourth club race at Botniaring in September, 61 entries. Fee 80,- euros and extra class 30,-
 - The season end ceremony and prize giving.

All events were satisfied from the financial point of view, all were on the positive side. SVKMK had few sponsors which made possible to have appropriate entry fees. Plan for club races 2024 is same kind as 2023.

- NMF: In Norway there have only been one classic race, a NC race at Våler with 200 riders, including the “modern” support classes: National and Super sport. The financial outcome was, thanks to the participation of the “modern” classes a plus. Two classes were scrutineered according to earlier Nordic meeting decision. On Saturday evening the CRC hosted a barbeque, celebrating their 30th anniversary. They served about 450 people.

During this year NMF have tragically lost one of their riders, due to a race incident at Årsracet.

The situation in Norway is declining, with decreased number of riders in both for modern and classic racing. A few of the classic riders also compete in “modern” classes. The financial strength of CRC has been improved year by year, which gives the space for letting other clubs organizing their NC race.

The number of road racing licenses in total are 730.

- SVEMO: Two international races have been held; Årsracet (NO) at Linköpings motorstadion och Classic TT (NC) at Gelleråsen. The number of entries were 232 (248) and 177 (190), a decrease compared to 2022. The financial results were +150' and -115' Sek., the later due to less participants than expected.

There were no classes picked out for special scrutineering this year, due to lack of personnel.

During Årsracet there was a tragic incident during the 500/750 race on Saturday. The outcome was that one rider died from the injuries and another was seriously wounded. The number of classic licenses during 2023 have been 117 + 10 for parade, a total increase with around 10% from the previous year.

7. Race Calendar 2024

Proposal

Jurva	24-26/5	NO + NC Finnish round
Våler	7-9/6	NO + NC Norwegian round
TBD	xx-yy/z	NO + NC Danish round TBD
Årsracet	2-4/8	NO
Gelleråsen	30/8-1/9	NO + NC Swedish round

This Calendar states the prioritized dates for classic racing in the Nordic countries. No national event is allowed to be planned, interfering with the dates above.

The date for the Danish race is planned to be sorted out during October. There are two major possibilities: the shift between June and July or the later part of September.

Clarification: It must be at least two weeks between Nordic races. No national races are allowed on those weekends.

If this move of the Finnish round will be permanent; Norway will look into the possibilities to move the race at Våler one week forward.

For 2025; ARC have declared that they want to arrange a race in 2025. This to celebrate the 30th anniversary of the Artic circle race track.

For 2024 Norway offered to handle the summarization for the points, which all other countries happily approved.

There are no known FIM-E events for 2024. Per will check with John Davidson if he has any updated information. The dates are supposed to be decided at a FIM-E meeting in November.

For the future, all countries are asked to share all race related dates between May and September, on the CRRC.DK platform as soon as they are known.

8. Proposals from the FMN's

8.1 There are no proposals from SML, but two points for discussion.

Federation:	SML
Discipline:	Classic Circuit Racing
Signed by:	Osmo Leikko
Date:	20.9.2023

Subject:	GP125 and GP125 status
-----------------	------------------------

<p>Proposal text:</p>	<p>I have been asked do GP classes have NC status.</p> <p>I found out that NMC 2010 Minutes of Meeting was written:</p> <p>“The swedish organization informed that they had invited the 250GP riders at the last race at Mantorp to come race at the swedish classic races 2011, either together with another class (e.g. Formula F2 or Supermono) or in a separate heat depending on the time schedule and amount of riders.</p> <p>The other nordic countries were encouraged to do the same and their response was very positive.</p> <p>The constraints of the time schedules at races is seen as the main hindrance, but there is still potential at many events to increase the efficiency.</p> <p>Finland, Norway and Denmark will investigate the possibility to invite 250GP for 2011 races, and it is seen as very likely that Mo I Rana and Botnia Ring will have time available.”</p> <p>NMC 2017 was written:</p> <p>“12.0 SVEMO: Allowing 125cc GP-machines to compete in class 12.</p> <p>Federation: Svemo</p> <p>Discipline: Classic Road Racing</p> <p>Signed by: Per Holmström</p> <p>Date: 2017-10-09</p> <p>Subject: 125cc 2-stroke GP production road racing machines 15 years and older and not belonging to any existing classic racing class should be allowed to compete in class 12 with 250 GP.</p> <p>Proposal text: Background:</p> <p>125cc 2-stroke GP production road racing machines 15 years and older are nowadays not competitive and therefore not used in modern road racing.</p> <p>When the class for 250 2-stroke GP-machines was abandoned in modern racing, MCHK-R found it suitable to welcome them in our arrangements in order to encourage interest, maintenance and use of these machines.</p> <p>The same arguments go for these older 125 GP-machines.</p> <p>Proposal: 125cc 2-stroke GP production road racing machines 15 years and older and not belonging to any existing classic racing class should be allowed to compete in class 12 together with 250 GP. Also non-production machines with proof of having competed in a national championship series should be allowed to participate.</p> <p>Decision: Approved; 125cc 2-stroke GP production road racing machines 15 years and older are allowed to compete in the 250 GP class.</p> <p>I didn't find Minutes of Meeting 2018.</p> <p>NMC 2020 was written:</p> <p>“8.4 Svemo proposal adding class 12 to the eligibility rules</p> <p>Federation: Svemo</p> <p>Discipline: Classic Road racing</p>
------------------------------	---

Signed by: Johan Edström

Date: 2020-tbd

Proposal in general

Since there are no existing official regulations for this class there is a need for written regulations for this class. Also, a clarification with the already existing allowance of using older 125GP machines in this class. And the addition of a possibility to compete with 500GP machines. Rules are based on the former existing FIM regulations for Grand-Prix racing at the end of the two-stroke era.

The eligibility rules are proposed to be altered with the following text:

Class 12

Type and age:

The class is open for two-stroke Grand Prix machines (factory-produced racing motorcycles, commonly called production-racers) from the 1986 model year to 2009. In addition, the class is open for 125GP and 500GP motorcycles produced between 1986 and 2009 and bikes or replicas of bikes that competed in the GP within the time frame.

Production based "sport-production" 250cc road legal motorcycles are also approved for the time being, as they were allowed when the class was run with National championship status until 2010.

And so on...

Purpose with proposal

250GP has been a support class to the Nordic classic-racing series for a long time and has been run without written-down regulations. Therefore, making it hard to judge what is allowed and what is not on the technical side. The hope is now to step up from being a support class and enter the classic-racing series as an official class with a little broader and attractive regulation. A new united name is needed, maybe something like, Class 12 Classic GP?

Decision: Approved with remarks; The rules will be incorporated in the eligibility rules bit with the additional remark that this class still will be a support class for the 2021 season"

Seems that GP125 and GP250 classes don't have NC status.

Should they have?

Is asking Osmo Leikko.

Vedict 8.1.1: Both GP 125 and GP 250 are full worthy classes in the Nordic Championship.

Reason: No new decision, only clarification of previous ones.

Federation:	SML
Discipline:	Classic Circuit Racing
Signed by:	Osmo Leikko
Date:	20.9.2023

Subject:	Technical inspection
-----------------	----------------------

Proposal text:	<p>I have been asked about technical inspection at Karlskoga.</p> <p>With no names there was asked about red rear light and told that it is too small. In the rules there is no mention about the size of the light, only bulb size. Someone did make their own rules?</p> <p>“All motorcycles in classes that are using slicks/rain tires shall be equipped with a red rear light. It shall be mounted at technical control but could be dismounted at dry race. The light shall be switched on when demanded by the competition leader. The light shall be clearly visible from any point behind the motorcycle. The brightness shall be equivalent to a 10-15 W normal bulb or 3-5 W LED. The light shall be steady, not flashing.”</p> <p>BUT, in latest FIM Europe regulations is written:</p> <p>“c) The luminous field should be at least 4cm² (e.g. rectangular 4 cm x 1 cm, circular Ø 2.25 cm).”</p> <p>Should that include to our rules also?</p> <p>Second thing was that inspector said that the helmet is too old.</p> <p>“FIM SUPERBIKE, SUPERSPORT & SUPERSPORT 300 WORLD CHAMPIONSHIPS REGULATIONS</p> <p>2.9.6 Riders must wear a helmet which is in good condition, provides a good fit, and is properly fastened.</p> <p>2.9.7 Helmets must conform to one of the recognized international standards: EUROPE ECE 22-05 (only “P” type) JAPAN JIS T 8133:2007 (valid until 31.12.2019) JIS T 8133:2015 (only “Type 2 Full face”) USA SNELL M 2010 (valid until 31.12.2019) SNELL M 2015”</p> <p>There is no mention about the age of the helmet.</p> <p>BUT, in latest FIM Europe regulations is written:</p>
-----------------------	---

“2.9.7 Helmet Standards

Helmets must comply with the FIM helmet standard.

A list of FIM Homologated helmets is available on www.frhp.org.

FIM FRHPhe-01 Compulsory from 01/01/2020



Should that include to our rules also?

I found text from 2014 Minutes of Meeting:

“10. Guideline for scrutenering?

Was started on last year’s meeting and Leo did a proposal for this. Bo takes the lead and comes up with a proposal before Christmas.”

I have never seen that document. Is it somewhere?

Is asking Osmo Leikko

Decision 8.2.1: For ease of understanding; we should add the text for the rain light, regarding size, from the FIM-E regulation.

Reason: It is regrated as a needed size in modern racing, and thereby we should use the same since the spray doesn’t deviate.

Verdict 8.2.2: Regarding regulation for helmets used for road racing; we need to follow the regulation from the federation that have issued the license. This due to the

connection to the insurance. We strongly advise the Nordic federations to agree on a common regulation for safety equipment.

Reason: The reason is that it will be very hard for the scrutineers to know the national deviations.

8.2 Svemo proposal approval of later rotax cylinders

PROPOSAL for adjusting the restriction on cylinders we remove the obstacle for many real roadracing bikes with Rotax engine to get back on track.

Federation:	Svemo
Discipline:	Classic Road Racing
Signed by:	<i>Karl Strandman and fellow Rotax drivers.</i>
Date:	220830

Subject:	Class: 7C F2. Due to limited supply of Rotax cylinders in general we wish to remove the restriction (casted year) in regulation. There is no major external difference as we can show in the pictures for later casted cylinders intill the production end of 1998. And as there is no tuning restrictions it should not be an issue to use all cylinders as long as they look like the cylinders externally within the time era.
-----------------	--

Proposal text:	<p>Describe the proposal in general</p> <p>Allow all Rotax produced cylinders casted till 1990. They must be identical to cylinders that was available within the period. There are no restrictions to tuning.</p> <p>During 58-Årsracet 2-4/8 2023 we had a meeting with Per Holmström and Osmo to show the cylinders in question. The latest cylinder we own is casted 1990. Per and Seppo inspected both the allowed cylinders and the 1990 cylinder and agreed on following:</p> <ul style="list-style-type: none"> - There is no major difference between 1990 cylinders and the present allowed 1987-88 cylinders and therefore Per and Seppo can agree on allowing Rotax cylinders casted till 1990. Option: If we can display any later casted cylinder then 1990 we may postpone the permitted year after inspection and updated proposal. <p>The eligibility rules are proposed to be altered with the following text</p> <p>Allow all Rotax produced cylinders casted till 1990. They must be identical to cylinders that was available within the period. There are no restrictions to tuning.</p> <p>The proposal has influence on the following paragraph.</p> <p>“TECHNICAL REGULATIONS FOR CLASS FORMULA 80-87 (Sanctioned at the Nordic Meeting 2020) Guidelines and examples of bikes and their legitimacy.</p> <p>Rotax 250 Cylinders of model year 87 and 88 that can be identified with cast in part no 223 350 (with exhaust valve) or 223 355 (without exhaust valve) are allowed. Model year 89 and later, part no 223 530 and 223</p>
-----------------------	--

~~535 is not allowed. Cylinders that are not identified with part no is not allowed.~~ Allow all Rotax produced cylinders casted till 1990. They must be identical to cylinders that was available within the period. There are no restrictions to tuning. *V-twin engines* are not allowed.”

Purpose with proposal

To allow the use of identical parts and thereby make it easier to build or maintain a motorcycle.

Due to limited supply of Rotax cylinders in general we wish to remove the restriction (casted year) in regulation. There is no major external difference as we can show in the pictures for later casted cylinders intill the production end of 1998. They look like the cylinders externally within the time era. With this we make way for Rotax powerd roadracing bikes to enter Classic Racing. They look like the cylinders externally within the time era. With this we make way for Rotax powerd roadracing bikes to enter Classic Racing.

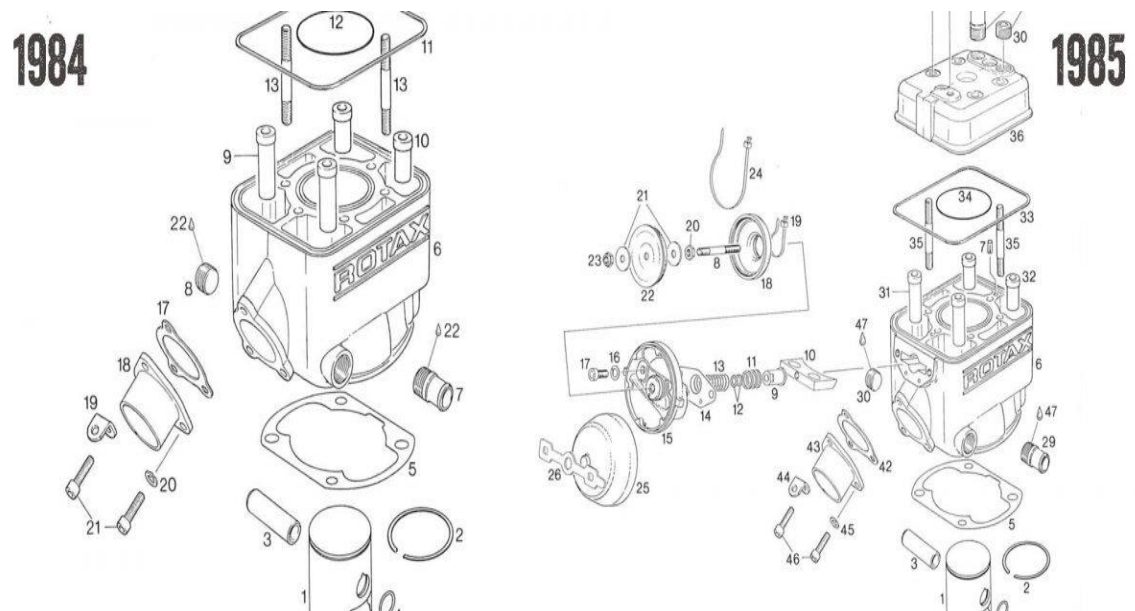

Bellow pictures of allowed cylinders on top and not allowed accordind to regulation today.

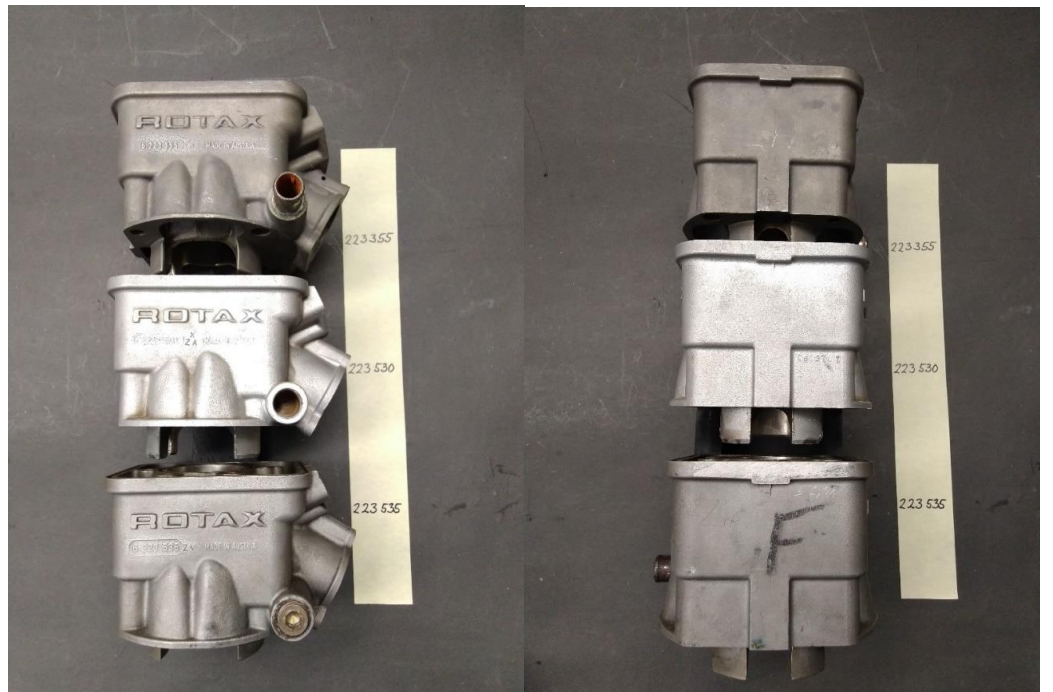
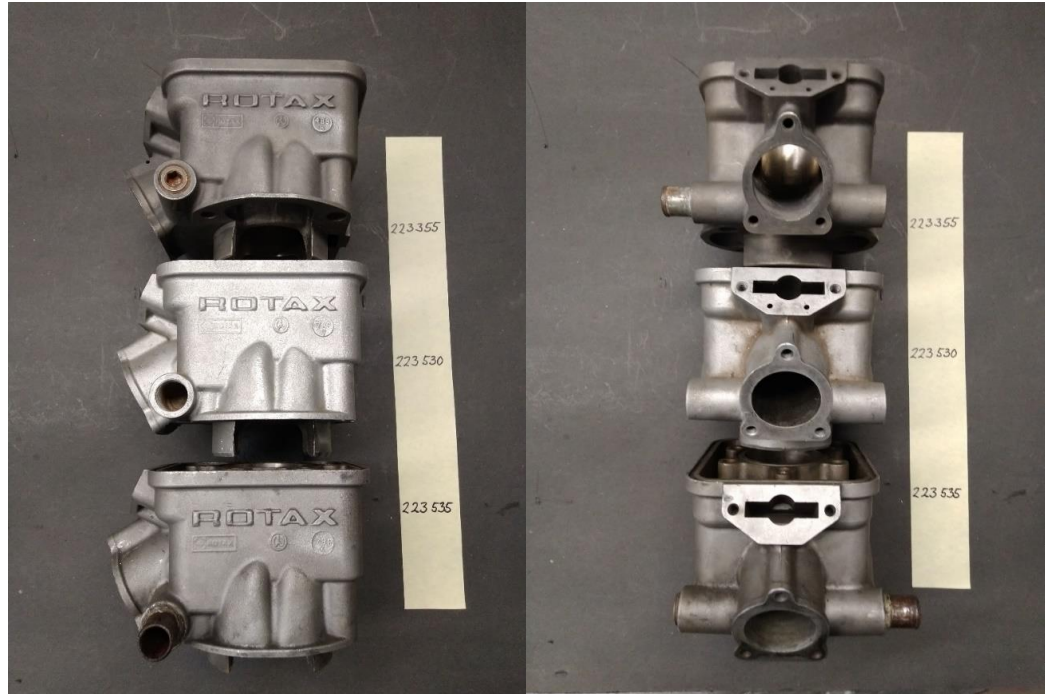

Part number 223530 casted 990 (september 1990)



Decision: Approved. These cylinders are shown for representatives in the Nordic machine committee and judged to be identical.
Reason: They are judged to be identical.

8.3 Svemo proposal approval of Brembo calipers

PROPOSAL for use of Brembo brake caliper type -75

Federation:	Svemo
Discipline:	Classic Road Racing
Signed by:	Ingemar Stig
Date:	20230910

Subject:	<i>Change in eligibility rules regarding Brembo brake callipers, valid for period 2 classes, i.e. classes 2, 3, 4, 5, and 6.</i>
-----------------	--

Proposal text:	<p>Describe the proposal in general <i>Allow the use of Brembo</i> brake callipers type 75 for period 2 classes, i.e. classes 2, 3, 4, 5 and 6.</p> <p>The eligibility rules are proposed to be altered with the following text Examples of eligible 2-piston brake callipers: 1. Brembo (the black calliper as fitted to Moto Guzzi T3). Both type 08 with single M10 bleed valve and type -75 with two M6 bleed valves should be allowed.</p> <p>Purpose with proposal <i>Since the type -75 preceded type 08 it should be allowed in above mentioned classes.</i></p>
-----------------------	---

Decision: Approved. The F08 are eligible independent if there are two m6 or one m10 bleeding screws. Add the following text to the regulation:

Under "Examples of eligible 2-piston brake callipers":

1. Brembo (the black caliper as fitted to Moto Guzzi T3). Both type 08 with single M10 bleed valve and the one with two M6 bleed valves is allowed.

Reason: Identical caliper types from a casting perspective. Only difference is the size and number of bleeding screws.

8.4 NMC proposal Move text stating the requirements for the origin of a bike.

PROPOSAL for moving text regarding the requirements for the origin of a bike.

Federation:	Svemo
Discipline:	Classic Road Racing
Signed by:	Classic NMC

Date:	20230924
Subject:	Move the text handling where and when a bike has been used from chapter 3.1.1 to chapter 1.0.

Decision: Approved. If any bike that are allowed today will be affected; that will be handled by state exemptions in the regulation for that particular class.

Reason: That rule is applicable for all classes.

8.5 Swedish proposals for discussion

Motion with proposals for changes 7C F1 and Classic Superbike and possibly. great forgotten era.

2023-09-11

Author Mats Winberg

Motion 1

Background.

7C F1 and Classic Superbike. I have thought that if a change is to take place, I believe that bikes before 1985, i.e. 1984 and below can be ridden in largely forgotten eras. If now forgotten the drivers welcome the proposal. Still, no one drives an older than 1985 in the 7CF1.

It is interesting that these bikes that were used then had a different chassis and were driven in the 500/750/1000cc class in Sweden. 1000cc, TT F1 regulations until 1983 then 750 until 1990. In 1991 it was Superbike with 750cc 4/cyl. 1000cc two/cyl. Very few used a standard frame before the Superbike era. Hard to believe that someone would start such a project today with the trimming and all the costs it entails. Actually, it would be max 750cc in F1, maybe with 1mm overbore for worn cylinder.

Exercise.

The proposal is model year 1987-1991 to be used in 7CF1. In this way, there will be more year models to choose from, than today, even then in largely forgotten eras.

Suggestions for additional bikes: Suzuki GSX-R750>1991 and 1100>1992 oil-cooled.

Yamaha FZR1000>1990 FZ750>1991 FZR750 OW01 Honda VFR750>1993 also RC30

Kawasaki GPX750 ZXR750>1990 GPZ900>1990 Ducati 851>1990

There are probably more, but I can't think of more.

Front fork may be upside down.

Verdict: No obvious benefits are seen with the proposal. One of the results will be that bikes that are compatible today, will not be that tomorrow.

Motion 2

Background.

Classic Superbike, the right thing is to set the limit to 2002 as it was the last year in the WSB with 750cc 4-cyl and 1000cc 2-cyl. In addition, there will be less ambiguity as to what is permitted or not. Now those bikes are 21 years old. And if you look at it from a historical perspective, the proposal is right. As it has become now, it is mostly an SRAD cup.

In addition, we get some interesting bikes from a historical perspective.

For example. Aprilia came out with their RSV in 1998 which we have as the last year, and was unchanged until 2003 is allowed with the current limit. All others are several years older. From 1999/2000, a number of new bikes came, e.g. from Suzuki, Honda and Yamaha which same were then unchanged until 2003 as well. Should reasonably be allowed to be used. The speed will not increase, it depends entirely on the driver. Possibly some drivers will be added. Finally, it will also be easier and cheaper with newer bikes to build racers on. Greater availability of parts.

Exercise.

The proposal intends to raise model years from now 1998 to > 2002. Same formula, 4 cyl. 750cc / 2 cyl. 1000cc. I.E. drive according to the superbike regulations empty. 2002. Very good for the future, then the 750cc era is completely over. Short and concise, 1992–2002, with the addition, the model is unchanged later so it can be used.

There aren't that many differences between the motorcycles until 2002, there will be more bikes to choose from.

Last if visible, change to white number bases and black numbers that apply to superbike. Black bottom valid now, have it on 7CF1.

Verdict: No obvious benefits are seen with the proposal. One of the results will be that bikes that are compatible today, will not be that tomorrow.

8.6 DMU proposal change no. 1: time period for two strokes.

PROPOSAL for 2023

Federation:	DMU	Danish proposal no. 1
Discipline:	Classic Road Racing	
Signed by:	Teddy Schultz, Denmark	
Date:	14.09.2023	

Subject:	Allow 2 strokes up to 1973 (all pre 1973 classes)
-----------------	---

Proposal text:	<p>Describe the proposal in general Removal of the restricted participation of two strokes that was implemented last year. Two strokes should participate in the respective classes under the exact same rules as four stroke bikes, as they did in the time period.</p> <p>Surguestion: Remove the restrictions from last year + remove the following marked in red. 35.1.1. Type and age: The machine shall be of racing type and comply with machines within the period (see §1.0). The machine shall have been available on the European market before or during the 1967 season for 2-strokes and 1972 for 4-strokes. A machine produced after these time limits are also eligible provided no change or updating has been done. If the organizer of the meeting regards it beneficial, the post war class can be divided in period 1 (produced until December 31st, 1963) and period 2 (produced from January 1st, 1964, until 1967 or 1972 as described above). Machines with 50 ccm cylinder volume shall have been available on the European market before or during the 1972 season regardless 2- or 4- stroke. For class 5 (500 ccm) only 4 stroke machines are eligible.</p> <p>Purpose with proposal The current setup is historical incorrect, two-strokes were raced in these classes before 1973. (Barry Sheene won the British national 500 Championship in 1971 on a Seeley/Suzuki T500)</p> <p><u>There is no argument to exclude or restrict the two-strokes from the pre 1973 classes.</u></p>
-----------------------	---

Decision: No new decision; it was partly approved last year: Alter the rules to allow two strokes from 68-72 to compete in the next class with larger capacity, e.g., 350 could compete in the 500 class. This is for a test period over the 2023 and 2024 season. The length of the test period could be re evaluated on next year's classic NMC.

Reason: The proposal decision is based on the same as the existing rule; to ensure tight racing. To that we've added that possibility for two strokes, with the same basis as we earlier have allowed 125-cc two stroke bikes, up to 1972, in the 175-cc class.

8.7 DMU proposal change no. 2: Frame and engine combination.

Federation:	DMU	Danish proposal no. 2
Discipline:	Classic Road Racing	
Signed by:	Teddy Schultz, Denmark	
Date:	14.09.2023	
Subject:	Frame and engine combination, all old classes (pre-1973)	

Proposal text:	<p>Describe the proposal in general.</p> <p>Remove the following text/rule:</p> <p>35.1.3. Frame and swinging arm: Shall be made from circular tubing that was used for road racing within the period. The swinging arm shall only have one tube each side. It is allowed to use newly manufactured frames to old specifications and to modify OEM produced frames. It is not allowed to combine frames and engines if the combination is not proved to have existed in the period.</p> <p>Or alternatively use the text from this chapter, which also allows to build your own frame</p> <p>34.3. Frame, swing arm: Original, replica or newly manufactured frames with period look is allowed. There are no restrictions to the suspension as long as it is typical for the period. Centrally located suspension units are only allowed on machines that originally were constructed that way.</p> <p>Purpose with proposal</p> <p>The authentic way to show RR/TT racers from the time period. In the time period there were only few riders who had the possibility to ride factory and special build racers bikes, the rest of the field were using anything available at that time. “home build” frames were also quite common.</p>
-----------------------	--

Decision: Rejected.

Reason: We shouldn't allow combination that weren't available, because we shouldn't rewrite the history.

The statement for having a machine card renewed for a bike that already have a machine card is that it is possible to alter the bike within the eligibility rules, but you need to keep the frame/engine combination.

8.8 NMF proposals for discussion

NMF didn't have any proposals to change any rules for this year; but they had the following points for discussion:

NMF for discussion 1

Federation:	NMF
Discipline:	Classic Roadracing
Signed by:	Classic Racing Club,
Date:	15.09.2023

Subject:	Number of riders, recruitment
-----------------	--------------------------------------

Proposal text:	<p>CRC has looked into the statistics of numbers of riders attending the race meetings and the trend over the last few years. We have seen a slight decrease in the number of attendants, especially in the old/small classes, but newer classes have so far made up for older ones.</p> <p>We can surely see that the riders have come back after the Covid pandemic, as the overall numbers for 2022 was back to the 2018/2019 level - very good!</p> <p>There is, however, a development of concern from the 2022 to the 2023 season, where there is a big decrease by 76 riders, and it seems like this mainly was about the Djursland race meeting, with 68 riders less than in 2022. It might be that the 2022 race in Denmark had especially high number of riders. Both Swedish meetings was each down by 14, and Våler up by 15, and Botniaring up by 5. The numbers are counted as riders who have started in a heat, completed or with a DNF.</p> <p>Looking closer at the numbers the reduction in Superbike was very large at Djursland, where the class is more than halved, from 33 to 15 riders, and no Swedish rider was attending In the Supermono class, where Danish riders traditionally do not attend, decreased from 13 to 4 riders.</p> <p>Any particular reason? The safety has been a point of discussion for a period? What about National races and Championship; Status and priority? No doubt the Nordic Championship has the highest status and has to come first. National races must come after the championship, and our organizers and riders need to be helped to understand this.</p> <p>The race calendar must have a good spread of the weekends for the races to make it easier for the riders to participate, and the National races have to be of second priority.</p> <p>Number of different riders starting in races, Open & Championship</p> <table border="1" style="width: 100%; border-collapse: collapse;"> <thead> <tr> <th colspan="2"></th> <th style="text-align: center;"><u>2018</u></th> <th style="text-align: center;"><u>2019</u></th> <th style="text-align: center;"><u>2022</u></th> <th style="text-align: center;"><u>2023</u></th> </tr> </thead> <tbody> <tr><td>Classic 1</td><td>Pre47</td><td style="text-align: center;">14</td><td style="text-align: center;">14</td><td style="text-align: center;">12</td><td style="text-align: center;">8</td></tr> <tr><td>Classic 2B</td><td>50AC&LC</td><td style="text-align: center;">25</td><td style="text-align: center;">23</td><td style="text-align: center;">27</td><td style="text-align: center;">24</td></tr> <tr><td>Classic 2</td><td>175</td><td style="text-align: center;">10</td><td style="text-align: center;">14</td><td style="text-align: center;">11</td><td style="text-align: center;">7</td></tr> <tr><td>Classic 3</td><td>250</td><td style="text-align: center;">17</td><td style="text-align: center;">14</td><td style="text-align: center;">13</td><td style="text-align: center;">14</td></tr> <tr><td>Classic 4</td><td>350</td><td style="text-align: center;">41</td><td style="text-align: center;">34</td><td style="text-align: center;">31</td><td style="text-align: center;">26</td></tr> <tr><td>Classic 5</td><td>500</td><td style="text-align: center;">27</td><td style="text-align: center;">29</td><td style="text-align: center;">25</td><td style="text-align: center;">24</td></tr> <tr><td>Classic 6</td><td>750</td><td style="text-align: center;">27</td><td style="text-align: center;">29</td><td style="text-align: center;">29</td><td style="text-align: center;">22</td></tr> <tr><td>7A</td><td>Forgotten era</td><td style="text-align: center;">43</td><td style="text-align: center;">42</td><td style="text-align: center;">40</td><td style="text-align: center;">26</td></tr> <tr><td>7B</td><td>Forgotten era</td><td style="text-align: center;">15</td><td style="text-align: center;">14</td><td style="text-align: center;">14</td><td style="text-align: center;">18</td></tr> <tr><td>7C F1</td><td>Formula F1</td><td style="text-align: center;">25</td><td style="text-align: center;">21</td><td style="text-align: center;">18</td><td style="text-align: center;">15</td></tr> <tr><td>7C F2</td><td>Formula F2</td><td style="text-align: center;">41</td><td style="text-align: center;">43</td><td style="text-align: center;">32</td><td style="text-align: center;">25</td></tr> <tr><td>8</td><td>Sidecar, A,B,C,D</td><td style="text-align: center;">28</td><td style="text-align: center;">18</td><td style="text-align: center;">31</td><td style="text-align: center;">20</td></tr> <tr><td>9</td><td>RD 350 LC</td><td style="text-align: center;">9</td><td style="text-align: center;">8</td><td style="text-align: center;">1</td><td style="text-align: center;">0</td></tr> <tr><td>11</td><td>Supermono</td><td style="text-align: center;">19</td><td style="text-align: center;">26</td><td style="text-align: center;">30</td><td style="text-align: center;">26</td></tr> <tr><td>12</td><td>GP 250&125</td><td style="text-align: center;">17</td><td style="text-align: center;">18</td><td style="text-align: center;">20</td><td style="text-align: center;">16</td></tr> <tr><td>13</td><td>Superbike</td><td style="text-align: center;">52</td><td style="text-align: center;">68</td><td style="text-align: center;">61</td><td style="text-align: center;">46</td></tr> <tr><td>14</td><td>Supersport 600</td><td style="text-align: center;">22</td><td style="text-align: center;">35</td><td style="text-align: center;">45</td><td style="text-align: center;">47</td></tr> <tr> <td colspan="2" style="text-align: right;">TOTAL</td> <td style="text-align: center;">432</td> <td style="text-align: center;">450</td> <td style="text-align: center;">440</td> <td style="text-align: center;">364</td> </tr> </tbody> </table>			<u>2018</u>	<u>2019</u>	<u>2022</u>	<u>2023</u>	Classic 1	Pre47	14	14	12	8	Classic 2B	50AC&LC	25	23	27	24	Classic 2	175	10	14	11	7	Classic 3	250	17	14	13	14	Classic 4	350	41	34	31	26	Classic 5	500	27	29	25	24	Classic 6	750	27	29	29	22	7A	Forgotten era	43	42	40	26	7B	Forgotten era	15	14	14	18	7C F1	Formula F1	25	21	18	15	7C F2	Formula F2	41	43	32	25	8	Sidecar, A,B,C,D	28	18	31	20	9	RD 350 LC	9	8	1	0	11	Supermono	19	26	30	26	12	GP 250&125	17	18	20	16	13	Superbike	52	68	61	46	14	Supersport 600	22	35	45	47	TOTAL		432	450	440	364
		<u>2018</u>	<u>2019</u>	<u>2022</u>	<u>2023</u>																																																																																																														
Classic 1	Pre47	14	14	12	8																																																																																																														
Classic 2B	50AC&LC	25	23	27	24																																																																																																														
Classic 2	175	10	14	11	7																																																																																																														
Classic 3	250	17	14	13	14																																																																																																														
Classic 4	350	41	34	31	26																																																																																																														
Classic 5	500	27	29	25	24																																																																																																														
Classic 6	750	27	29	29	22																																																																																																														
7A	Forgotten era	43	42	40	26																																																																																																														
7B	Forgotten era	15	14	14	18																																																																																																														
7C F1	Formula F1	25	21	18	15																																																																																																														
7C F2	Formula F2	41	43	32	25																																																																																																														
8	Sidecar, A,B,C,D	28	18	31	20																																																																																																														
9	RD 350 LC	9	8	1	0																																																																																																														
11	Supermono	19	26	30	26																																																																																																														
12	GP 250&125	17	18	20	16																																																																																																														
13	Superbike	52	68	61	46																																																																																																														
14	Supersport 600	22	35	45	47																																																																																																														
TOTAL		432	450	440	364																																																																																																														

Nordic Classic Roadracing, statistics 2023

Figure 1: Total number of start-grid entries in the season, by race meeting, 2022 and 2023

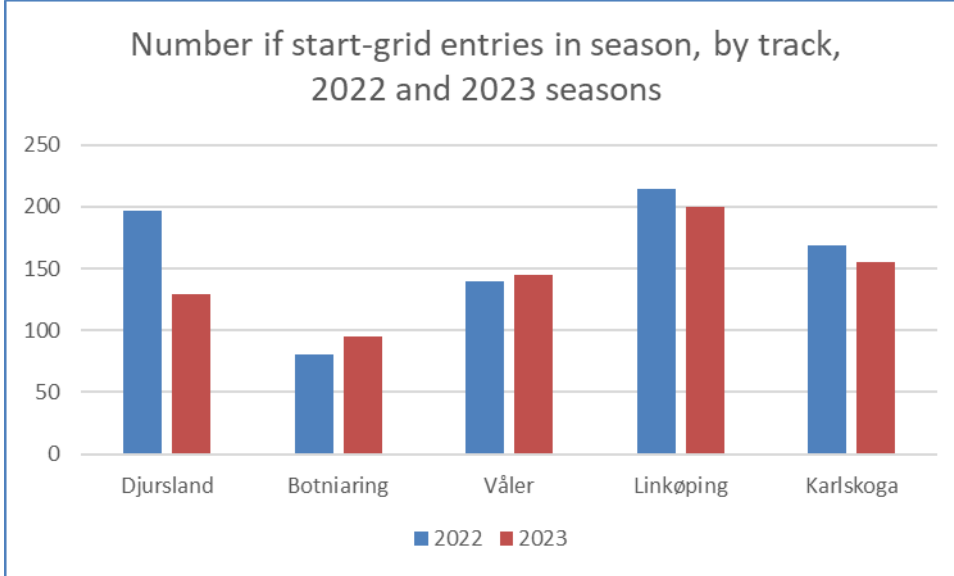

Figure 2: Total number of start-grid entries in the season, by class, 2018 to 2023

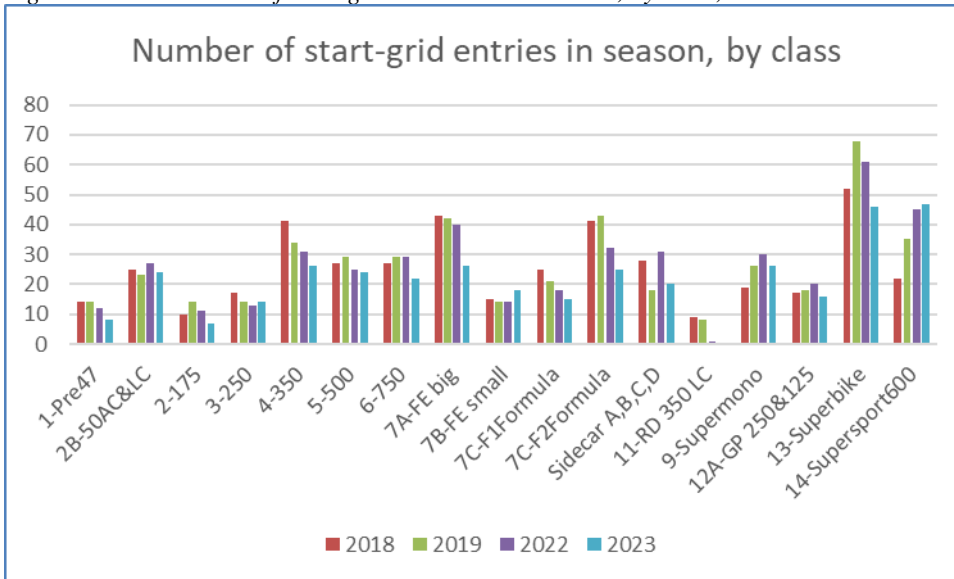

Figure 3: 2023 only. The number of race meetings that each rider is attending (total of 289 riders)

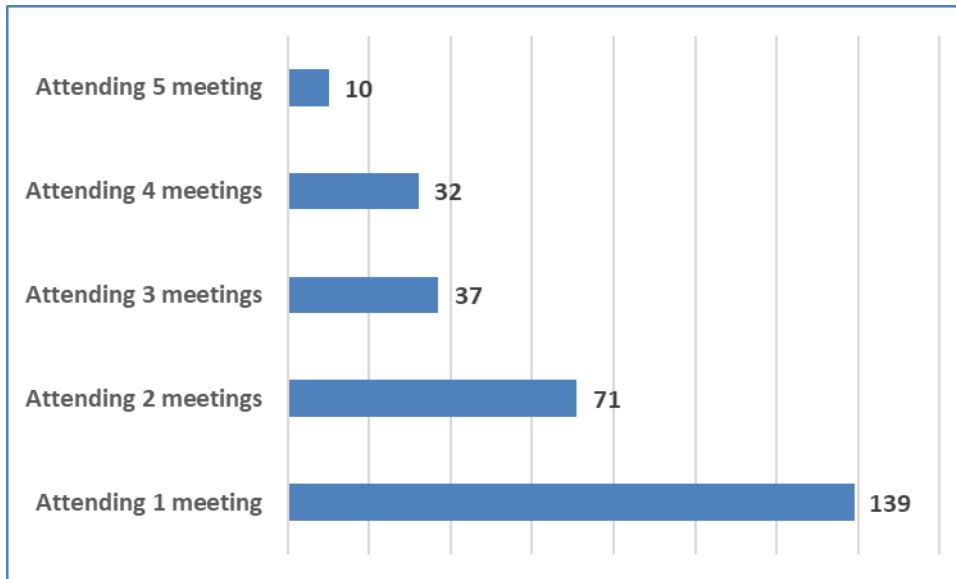

Figure 4: 2023 only. The number of classes each rider is starting in (total of 289 riders)

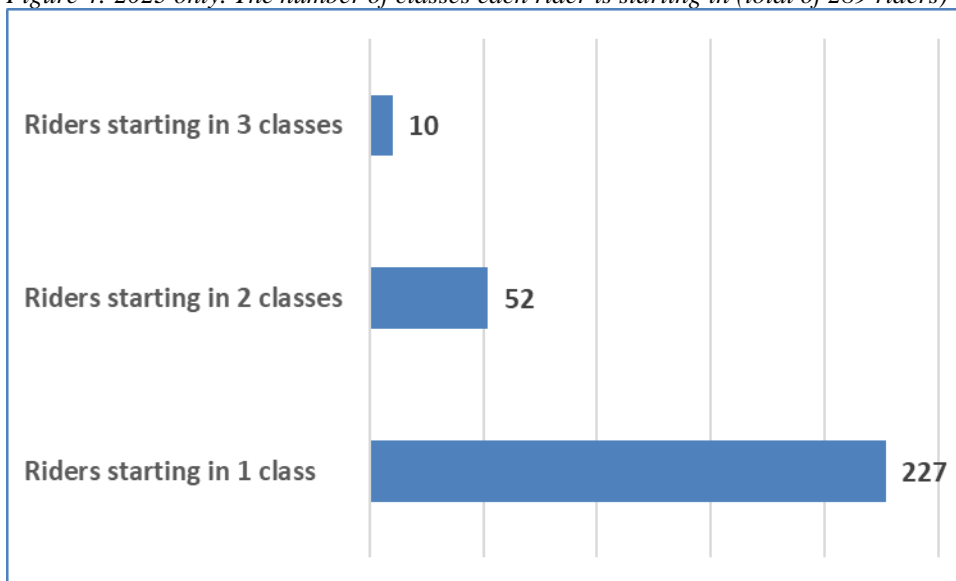

Table 1: 2023 only. Number of riders attending what number of meetings, by rider's nationality

Rider Nationality	Attending 1 meeting	Attending 2 meetings	Attending 3 meetings	Attending 4 meetings	Attending 5 meetings	TOTAL
DEN	62	9	4	1	-	76
FIN	22	3	3	2	-	30
NOR	20	15	8	13	3	59
SWE	27	42	22	16	7	114
GER	6	-	-	-	-	6
NED	2	2	-	-	-	4
						289

Vedict: Should be seen as information only and to be used for the future.

NMF For discussion 2

Federation: NMF
Discipline: Classic Roadracing
Signed by: Classic Racing Club,
Date: 15.09.2023
Subject: Safety

Proposal text: After the tragic accident at Sviestad, it has been discussed whether a tag or a marking of our leathers, of the rider or both would help the marshals and medics to faster identify the riders after a crash involving several riders.

We can probably not decide anything regarding a change of the general regulations for road racing, but we can encourage our riders to think about using a tag.

In UK you got to wear a tag

Verdict: We strongly recommend that all riders should order and wear a tag. The recommendation for the future is that this should be checked at scrutineering. Add picture of the Swedish tag to get what information that should be there.

Reason: In case of an accident; necessary information could fast and easily be obtained by the medical personnel.

NMF For discussion 3

Federation: NMF
Discipline: Classic Roadracing
Signed by: Classic Racing Club,
Date: 15.09.2023

Subject: Prize ceremony Nordic Championship, Race of the year

Proposal text: After the finals at Karlskoga some riders were disappointed about the prize ceremony for Nordic Championships, it is an achievement to become a Nordic Champion, and that deserves some celebration.

What can we do to give our champions the attention deserved?

Did we end the championship on Saturday in earlier years with the prize ceremony on Saturday night, and did we only ride a "Race of the year" on Sunday?

If we do like that, the race of the year can count in the Nordic Open. That is a cup and do not have status like a championship.

Verdict: We strongly recommend that the organizer of the last race of the year do have an official prize giving ceremony for the Nordic Championship.

Our proposal is to run free practice and timed practice on Friday. Running two heats on Saturday and than have a "Race of the year", that also will be part of NO, on Sunday.

We are aware of that the number of laps could be affected.

Reason: To be able to have a proper prize giving ceremony for the Nordic Championship. It is an achievement to become a Nordic Champion, and that deserves some celebration

9. Additional verdicts

The decision regarding brake calipers, taken at the classic NMC 2022 need to be updated due to a mistake in the line of communication.

Discussion regarding brake callipers in Formula F1 and F2

Since the used "blue spot" callipers weren't available in 1987, the outcome from the discussion is that no change of the rules are needed. During the upcoming season the riders with these callipers should be informed at their first race meeting the calipers should be changed before attending their second race meeting. This information should be seperatly spread via our social medias.

10. Next years NMC

Next years classic NMC are planned to be held in advance of the big NMC. We plan for a physical meeting at least two weeks before the "big" NMC. The "big" NMC are usually held in October. Finland will arrange the meeting.

2023-09-24

Secretary

Per Holmström

Chairman

Tor-Henning Molstad